

Stepper, BLDC and DC Motor Controller

8SMC4-USB series

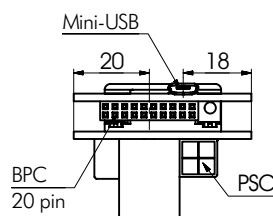

8SMC4-USB-B8-1
One Axis Controller

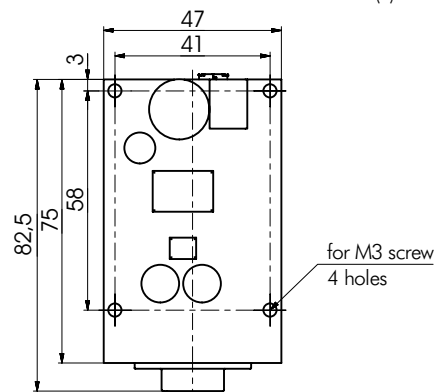
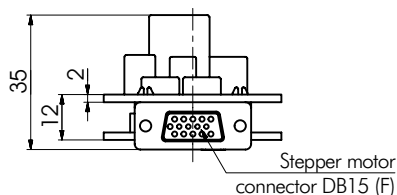

8SMC4-USB
Circuit Card Assembly

- Compatible with Windows XP/Vista/7/8, Linux, Mac OS
- Saving settings files to flash/file
- Precise home positioning
- Synchronization I/O
- User Friendly XILab Interface
- Step Mode Up to 1/256
- Rated current up to 3 A for stepper; 6 A for DC motor
- Voltage 5 V – 36 V
- Code Examples for Visual Basic, C, C#, C++, Matlab, Labview
- Ready to use Configuration files for Standa stages
- Status LEDs
- Max. speed – 35000 steps/s (stepper); 800000 encoder counts per second (DC)
- Encoder Input
- Compatibility with 8SMC1-USBhF
- Supports up to 32 axes in single USB port (more on request)
- Manual control buttons
- USB Interface



Brief description

An overview of today's approaches for flexible motion control in lab experiments is given. With modern controller design even simple and inexpensive positioners can be utilized to achieve high speed and precision. It doesn't matter which motor technology you prefer: stepper, DC, or BLDC because one controller can drive them all. Multi-axis control, developing custom motion control software for any OS, automatic positioners recognition and using various peripherals are all easy now.

Supported types of motors

The controller is great at driving bipolar stepper motors with a rated winding current of up to 3 A (by request up to 6 A, 48 V) and DC motors with rated current up to 6 A. All you need to do is plug it in, no assembly required.

Multiple controllers can be connected to one computer either via USB ports or through a special hub that provide axis synchronization.

The controller's software is fully compatible with almost all operating systems, e.g., Windows, Mac OS X, Linux, etc. You can test the software with virtual controllers simulated by the software. The software provides javascript like scripting language to quickly automate your task or you can use a cross platform library with code examples on C, Visual Basic, Matlab, Labview, C# to build your own software.

Optionally the controller can be managed with the same instructions set, as from USB interface, by using many of popular serial interfaces like Bluetooth, Ethernet, RS422 or RS232 – requires converters from TTL logic signals RX and TX. These signals are located on the backplane connector of the controller circuit board. Communication speed, parity and stop bits are wide configurable. Default interface is USB, but on request Standa can produce controllers with required interface. Test the controller 8SMC4 instantly as it comes with the manual control buttons, they could be used for ease testing of your equipment or controller itself even without a PC.

Software

XILab features two user-friendly graphical interfaces, which are designed for positioners control, diagnostic and fine tuning of the motors driven by the controllers. The control process can be automated with the scripting option that can be used either directly or to speed up the process of customized control program development. XiLab supports multiaxial mode and multidimensional control scripts. It is possible to output motor and controller status in form of charts and save them to a file. XILab software has two types of interfaces: Single-axis control and Multi-axis control.

Single-axis and Multi-axis control interfaces contain motor and controller parameters: position, speed, voltage, current and temperature. Advanced joystick and units conversion block are only available in Multi-axis interface. You can choose any of these interfaces that fits your application the best.

SPECIFICATIONS

Winding current	
stepper	0.25 – 3 A
DC	0.25 – 6 A
Power supply	12 – 36 V
Step division	1 – 1/256
Max speed	
stepper	35000 steps/s
DC	800000 encoder counts per second
Motor connector	DB15F
Synchronization	YES
ESD protection	YES
Interface	USB, COM port
Operating Temperature,	up to 70 °C
LED indication	YES

One controller!
One interface for any type of motor!
Bipolar Stepper
(rotational/linear)
DC
BLDC
(rotational/linear)

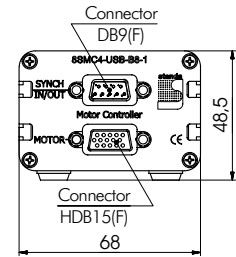
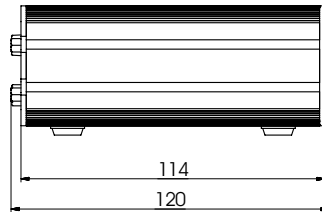
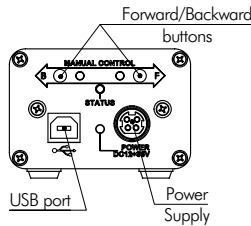

8SMC4-USB-B8-1
One Axis Controller

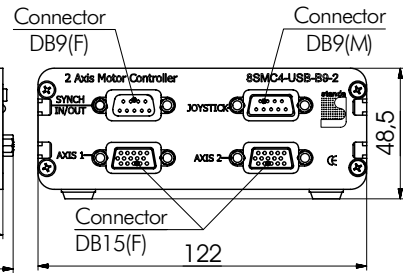
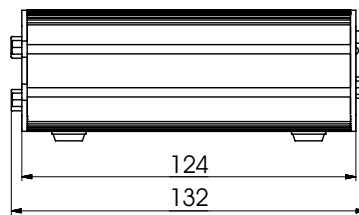
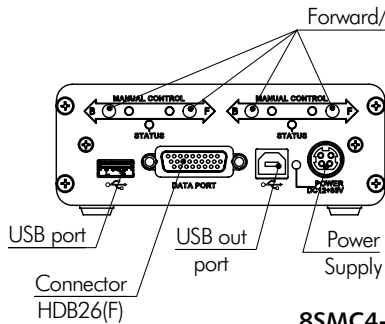

8SMC4-USB-B9-2
Two Axis Controller

8SMC4-USB-B8-B9
Three Axis Controller



8SMC4-USB-B9-B9
Four Axis Controller



Ordering information

<p>1 Optical Tables</p>	<p>8SMC4-USB 8SMC4-USB-B8-1 8SMC4-USB-B9-1 8SMC4-USB-B8-1BR 8SMC4-USB-B9-1BR 8SMC4-USB-B9-2 8SMC4-USB-B9-2BR 8SMC4-USB-B8-B9 8SMC4-USB-B8-B9-BR 8SMC4-USB-B9-B9 8SMC4-USB-B9-B9-BR</p>	<p>- 1-axis controller circuit card assembly - 1 axis controller / budget - 1 axis controller - 1-axis controller for brake equipped motor / budget - 1-axis controller for brake equipped motor - 2-axis controller - 2-axis controller (1-axis for brake equipped motor) - 3-axis controller - 3-axis controller (1-axis for brake equipped motor) - 4-axis controller - 4-axis controller (1-axis for brake equipped motor)</p>
<p>2 Brackets & Rails</p>	<p>5AK-B9-B9 8A-KPPX-KPJX 8CA-SYNCH 8CA15F-15MR12 1.8 m 8CA15M-15F/BR/SYNCH 8CA9F-15MR 1.8 m 8HDB26M</p>	<p>- Assembly kit to fix two or more controller boxes together - Power supply output cable split - Synchronization cable - 15-pin cable to motor with rotary encoder - 15-pin cable to motor with brake and synchronization - 9-pin cable to motor - Connector HDB26(M) with backshell</p>
<p>3 Base Mounts & Accessories</p>	<p>8JXY-03 Cable12-L1.8 Cable8-L1.8 USB/A-B 0.2 m USB/A-USB/B 1.8m USB/mini-USB/A</p>	<p>- 2-axis joystick for manual control - 12 core cable, lenght 1.8 m - 8 core cable, lenght 1.8 m - USB cable between controllers 0.2 m - USB cable to PC 1.8 m - mini USB cable to PC</p>

Joystick

NEW

8JXY-03



- Easy plug in connection
- High precision
- Spring return to center position mechanism
- Hall Effect sensor type
- High Life cycles
- Operating temperature -25°C up to +70°C
- IP class is For Indoor usage
- Deflection X/Y max. $\pm 18^\circ$

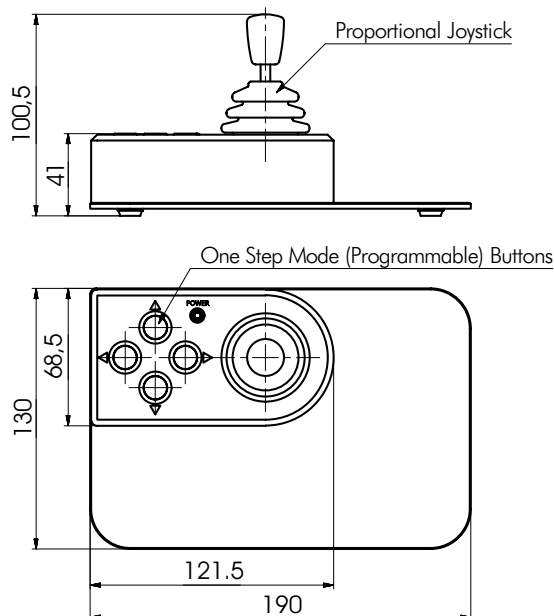

Easy and ergonomic joystick 8JXY-03. Joystick developed for manual control of one or two-axis all Stepper motor equipped motorizes stages, which provide smooth motion with proportional **joystick**, and one step mode (programmable) motion with **4 buttons** on top. Joystick suitable for Standa stepper motor controllers and parameters like: **acceleration, deceleration and speed changing in time** – can be programmed for your application and task. Proportional joystick's knob made of nylon and very ergonomic, what in aggregate with wide joystick base provides usage stability and comfortability during work.

4
Optical
Mounts

5
Optical
Positioners

6
Base
Positioners

7
Translation &
Rotation
Stages

8
Motorised
Positioners &
Controllers

9
Fine
Adjustment
Screws

10
Opto-
Mechanics &
Sets

11
Light Test &
Measurement
Instruments

12
Lasers &
Laser
Accessories

Power Supplies for Standa Controllers



Power supply PSAA18U-120
 12 V; 1.5 A
 98.5 × 55 × 31.5 mm
 200 g
 connector “2.1/5.5”



Power supply PSC30U-120V
 12 V; 2.5 A
 98.5 × 55 × 31.5 mm
 250 g
 connector “2.1/5.5”



Power supply GS60A24-P1
 24 V; 2.5 A
 125 × 50 × 31.5 mm
 310 g
 KPPX-4P power connector



Power supply PUP120-17
 36 V; 3.34 A
 167 × 65 × 37 mm
 640 g
 KPPX-4P power connector

Standa stepper motors and DC motor controllers require properly matched power supplies for operation.

Current requirements for stepper motor controller power supplies:

During operation, current consumption will vary depending upon how the controller is being used. Before shipment, our controllers are calibrated to the rated current of the motors they are to be used with. If you do not specify a motor, the controllers will be calibrated to a factory default value. Due to Pulse Width Modulation (PWM) our controllers usually consume less current than the rated current

of motors. However, to avoid problems during worst case scenarios, we recommend selecting a power supply with a max current not less than the rated current of motors that will be connected to the controller. In case of multi-axis controllers you will need to sum the currents of all controllers connected to the power supply.

Requirements for stepper motor controllers power supply voltage:

Our stepper motor controllers are a “chopper drive” type. This means that in the initial phase of the motor step our controller will apply significantly higher voltage to motor winding than will occur in other drive types. This method allows stepper motors to be driven with higher torque at higher speeds. It

should also be noted that stepper motor parasitic resonant effect behavior (“bad” frequencies position, for example) depends on supply voltage. Minimal allowable DC voltage of our stepper motor controllers is 12V and maximum is 36V, both of which we keep in stock.



www.standa.it

e-mail: sales@standa.it



Phone: +370-5-2651483

Fax: +370-5-2651474

